

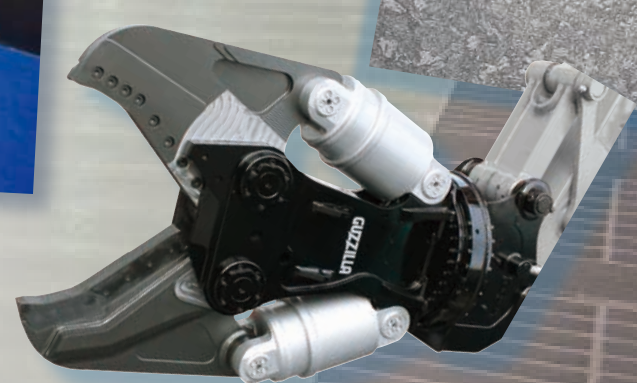

# Guidelines for fabrication JFE's Abrasion-Resistant Steel Plate **EVERHARD™**

- BENDING -

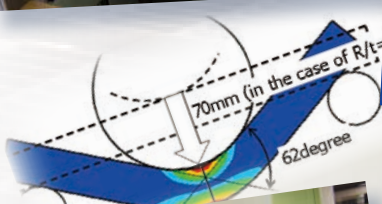



## Contents

Guidelines for Fabrication of JFE's Abrasion-Resistant Steel Plate	
EVERHARD: Bending .....	1
For High Quality Bending .....	2
Storage .....	2
Checkpoints for Bending .....	3
Guidelines for Minimum Bending Radius.....	4
Guidelines for Edge and Surface Preparation .....	6
Bending Force .....	7
Springback.....	9

"EVERHARD" is a registered trademark of JFE Steel Corporation in Japan.

# Guidelines for Fabrication of JFE's Abrasion-Resistant Steel Plate EVERHARD: Bending

In 1955, JFE Steel began manufacturing abrasion-resistant steel plates before any other mills in Japan. Since then, this product, trade-named "EVERHARD", has been used in a wide range of applications, beginning with industrial machinery and also including equipment for civil engineering and construction, mining equipment and agricultural machinery. Today, EVERHARD is recognized as an indispensable product that ensures complete customer satisfaction.

This catalog, "Guidelines for fabrication of JFE's Abrasion-Resistant Steel Plate EVERHARD: Bending," is prepared so that all customers can utilize the outstanding performance of EVERHARD effectively and with full confidence. We hope that the information contained herein will help customers' business.

Thank you for using EVERHARD, and we look forward to serving you in the future.

## ■ Features of EVERHARD

Type	Features	Brand name
<b>C</b> <b>(Standard Series)</b>	General-purpose EVERHARD products. Economical alloy design with priority on hardness of steel plates. Surface hardness is controlled in narrow range, which reduces variations in formability.	<b>EVERHARD-C340</b>
		<b>EVERHARD-C400</b>
		<b>EVERHARD-C450</b>
		<b>EVERHARD-C500</b>
		<b>EVERHARD-C550</b>
		<b>EVERHARD-C600</b>
<b>C-LE</b> <b>(High Toughness Series)</b>	Guarantees low temperature toughness at -40°C (-40°F). Full lineup of abrasion-resistant performance up to Brinell hardness 500 grade. Alloy design which considers internal hardness.	<b>EVERHARD-C400LE</b>
		<b>EVERHARD-C450LE</b>
		<b>EVERHARD-C500LE</b>
<b>SP</b> <b>(Super Abrasion-Resistant Series)</b>	EVERHARD that outperforms EVERHARD. Provides abrasion resistance exceeding Brinell hardness 500 grade.	<b>EVERHARD-SP</b>

This catalog was prepared based on the technology in efforts to improve the performance of EVERHARD at the present time and thus is subject to change with progress in development. As this technical information describes the representative features of EVERHARD, JFE Steel Corporation cannot accept responsibility for compatibility in individual cases; however, in case of problems, please feel free to consult with the company.

## For High Quality Bending

To ensure that all customers can use EVERHARD safely, economically and with full confidence, these guidelines summarize the basic processing parameters for bending, including the selection of materials, bending processing parameters, condition of the plate surface and edges, etc.

When performing bending of abrasion-resistant steel plates, selection of the optimum bending conditions such as bending radius, cross-sectional quality is important because they have high strength and hardness in comparison with general structural steel plates. When a steel plate is bent, mechanical force exceeding yield point bring about strain and deforms steel plate plastically resulting in shape change. The strain generated at the outer surface of the plate during bending increases as the thickness of the plate increases or the bending radius decreases. Cracks occur when the strain acting on the outer surface of the plate exceeds the allowable limit strain of the plate. Whether cracks occur or not is influenced by the mechanical properties, bending direction, width of the plate, the conditions of the plate edge and surface, the forming temperature, and other factors.

A schematic diagram of the conditions for occurrence of cracks is shown below. Occurrence of cracks are affected by the intrinsic properties of the steel plate, the dimensions of the plate and bending radius; the condition of the plate surface and edge; and the environment in which bending is performed.

General precautions for bending are summarized by items on the following page.

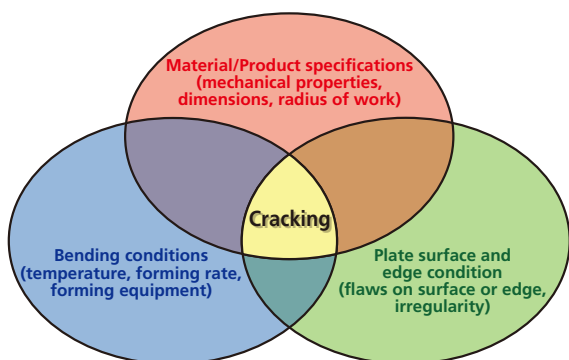

Example of crack which occurred during bending

## Storage

EVERHARD plates should be stored so as to avoid bending and twisting. Use waterproof sheets to prevent rust and pitting due to corrosion, which can cause cracking. When using a waterproof sheet, ventilate occasionally to reduce humidity under the sheet.

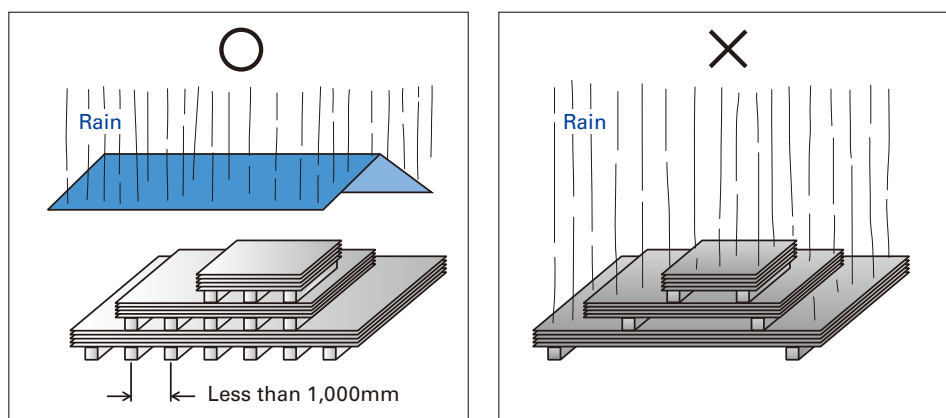

Fig. Recommended storage method

# Checkpoints for Bending

## ■ General Precautions

Item		Recommendations and precautions
1	<b>Selection of steel grade</b>	<ul style="list-style-type: none"> <li>To reduce variations in bending by the customer, we recommend the EVERHARD C Series, in which the upper limit of surface hardness is set and guaranteed within a narrow range.</li> <li>Bending becomes more difficult and cracking occurs more easily as material hardness increases. Therefore, EVERHARD-C550 and EVERHARD-C600 are not recommended.</li> <li>If you intend to bend the EVERHARD plates other than the EVERHARD C Series, please consult with JFE Steel in advance.</li> </ul>
2	<b>Bending radius</b>	<ul style="list-style-type: none"> <li>Bending becomes more difficult as material hardness increases. Please refer to the recommended minimum bending radii shown on the following page.</li> </ul>
3	<b>Bending direction</b>	<ul style="list-style-type: none"> <li>Material should elongate in the plate rolling direction (longitudinal direction) by bending. Punch of press bending machine or axe of bending roll should be placed in the direction perpendicular to the rolling direction (*When using plates with surface markings, the direction of the letters indicates the longitudinal direction).</li> </ul>
4	<b>Plate width</b>	<ul style="list-style-type: none"> <li>In comparison with narrow width plates, cracks may occur easily in wider plates, even with the same bending radius. In general, the effect of plate width appears when the width is 7-10 times the plate thickness or more.</li> </ul>
5	<b>Edge condition</b>	<ul style="list-style-type: none"> <li>Stress concentrates at notches on a gas-cut cross section or burrs on a sheared section in bending. Cracks may initiate from such points (called the "notch effect").</li> <li>Before bending, notches or burr should be removed as far as possible by R-chamfering or C-chamfering with a mechanical grinder.</li> </ul>
6	<b>Surface condition</b>	<ul style="list-style-type: none"> <li>There is a possibility that surface flaws or rust may become a point of origin for cracking. Any flaws and rust should be removed by grinding before bending.</li> <li>Flaws (scratches, etc.) or roughness on the punch or die of the bending machine may cause transferred flaws or roughness on the surface of the EVERHARD plate. Strain concentrates at transferred flaws/roughness on the surface, and could cause points of origin for cracks. Therefore, any such flaws should be removed by grinding in the stage before bending.</li> </ul>
7	<b>Ambient temperature</b>	<ul style="list-style-type: none"> <li>In case the ambient temperature where bending is to be performed is 0°C or less, we recommend preheating to approximately room temperature (around 20°C).</li> <li>If EVERHARD is heated to a temperature exceeding 200°C during preheating, the properties of the plate will change. Implement proper control by temperature measurement of the actual plate, etc. to ensure that the temperature of the plate does not exceed 200°C.</li> <li>After preheating, check to be sure that the temperature of the plate has decreased to room temperature (around 20°C) before performing bending.</li> </ul>
8	<b>Unbending</b>	<ul style="list-style-type: none"> <li>It should be avoided to bend the plate in the direction opposite to the final shape, and then bent in the direction opposite to that direction (so-called "unbending") as bending cracks may occur easily.</li> </ul>



Note to No. 6 Example of flaws remaining on tool of forming device.

# Guidelines for Minimum Bending Radius

The minimum bending radius (curvature) recommended in bending of EVERHARD differs depending on the steel grade and bending direction. Guidelines for the minimum bending radius are shown in the following table.

## Recommended Minimum Bending Radius

Brand name (grade)	Bending direction	
	Perpendicular to rolling direction	Parallel to rolling direction
JFE-HITEN780LE	2.0 t	2.0 t
JFE-HITEN980S	2.5 t	2.5 t
EVERHARD-C340	3.0 t	4.0 t
EVERHARD-C400	3.5 t	4.5 t
EVERHARD-C400LE		
EVERHARD-C450	4.5 t	5.5 t
EVERHARD-C450LE		
EVERHARD-C500	5.5 t	6.5 t
EVERHARD-C500LE		
EVERHARD-C550	Bending is not recommended.	
EVERHARD-C600		
EVERHARD-SP	5.5 t	6.5 t

\* The recommended minimum bending radius is a guideline for the limit bending radius at which cracking will not occur when bending the various grades of EVERHARD. For example, when bending EVERHARD-C400 with the plate thickness of 20 mm perpendicular to the rolling direction, from the above table, the minimum bending radius is  $3.5 \times 20 = 70$  mm. The bending radius, therefore, should be larger than this limit value.

## Metallic Materials – Bend Test (JIS Z 2248)

The guidelines for the limit bending radius recommended by JFE Steel were decided based on the results of bending tests in accordance with JIS Z 2248, Metallic Materials – Bend Test.

The minimum bending radius is influenced by the width and plate thickness of the test piece. The recommended minimum bending radii were obtained by using actual EVERHARD specimens with the wider width of 150 mm and thickness of 12 mm. The dimension of the specimen was determined by the analysis of these test piece geometries. Minimum bending radii shown above are recommended as strict conservative minimum values.

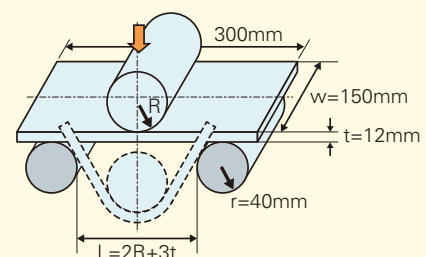

Geometry of bending test piece (JIS Z 2248)

## ■ Examples of Characteristics

### Bending by press forming machine

The following shows examples of bending by press forming. Because the results shown below were obtained by tests to measure the limit properties of the material, we recommend that customers perform bending with the recommended minimum bending radius when using EVERHARD.

Brand name (grade)	Product thickness mm	Bending conditions							
		Test specimen thickness mm	Test specimen width mm	Bending direction and bending angle	Bending radius / Specimen thickness ratio				
					1.0	1.5	2.0	2.5	3.0
JFE-HITEN780LE	12	12	150	Perpendicular to rolling direction 180°	○	○			
JFE-HITEN980S	8	8			○	○			
EVERHARD-C340	140	12*			×	○	○		
EVERHARD-C400	12	12				×	○	○	
EVERHARD-C450	12	12					×	○	○
EVERHARD-C500	12	12						×	○
EVERHARD-SP	35	12*						×	○

○ : No cracking × : Cracking occurs

\*Reduction was performed from the product thickness by reduction from the back side of the plate, while leaving the surface scale.

### Bending by roll bender

This table shows examples of bending using a roll bender. The recommended minimum bending radius is not proposed, as it is difficult to obtain the minimum bending radius in bending with a roll bender due to the limitations of the equipment. However, bending can be performed with a bending roller under the conditions shown below.

Brand name (grade)	Product thickness mm	Bending conditions				
		Roll diameter mm	Test specimen thickness mm	Test specimen width mm	Bending direction	Bending radius / Specimen thickness ratio
						8.3
EVERHARD-C400LE	12	200	12	200	Perpendicular to rolling direction	No bending occurred when plate is bent to fit to the roll diameter
EVERHARD-C450LE						
EVERHARD-C500LE						

# Guidelines for Edge and Surface Preparation

Because stress concentrates at flaws, cracks occur easily in those parts. If the condition of the edge or surface of a steel plate is poor, the parts where flaws exist should be finished smoothly with a mechanical grinder, etc. as shown in "Checkpoints for Bending"

The following presents examples of the results of FEM analysis for cases where the finished shape of the plate edge was changed.

In case of a remaining notch, as shown in (b), stress concentration can be observed in the bottom of the notch.

In general, the effect of a notch can be eliminated by producing a smooth finish in which the notch width/depth ratio is at least 10:1.

## ■ Results of FEM Analysis of Condition of Deformation during Bending

(a) Smooth edge (ideal)

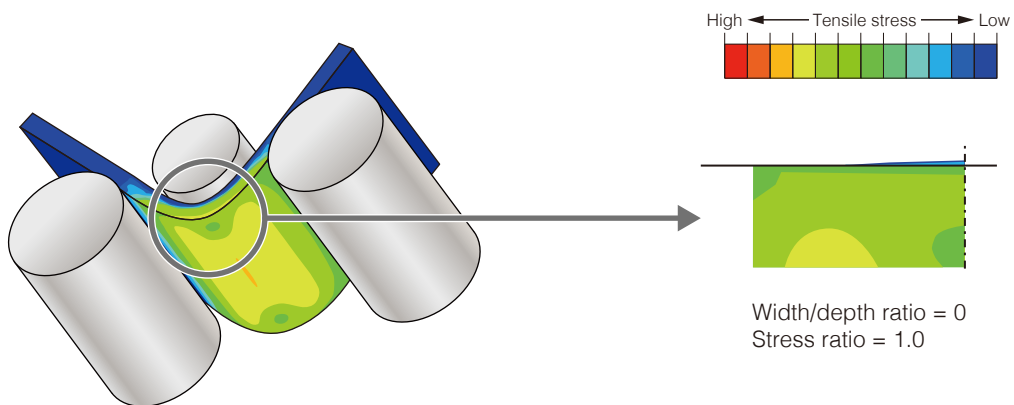

(b) Remaining notch

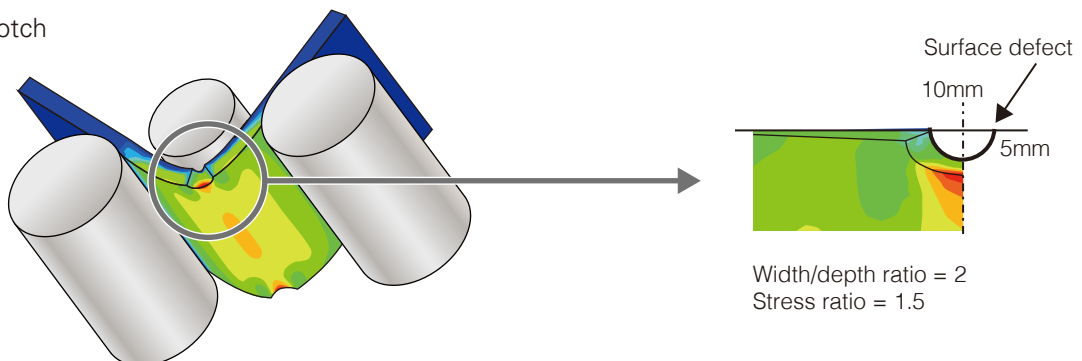

(c) Finishing with mechanical grinder to width 10x the notch depth

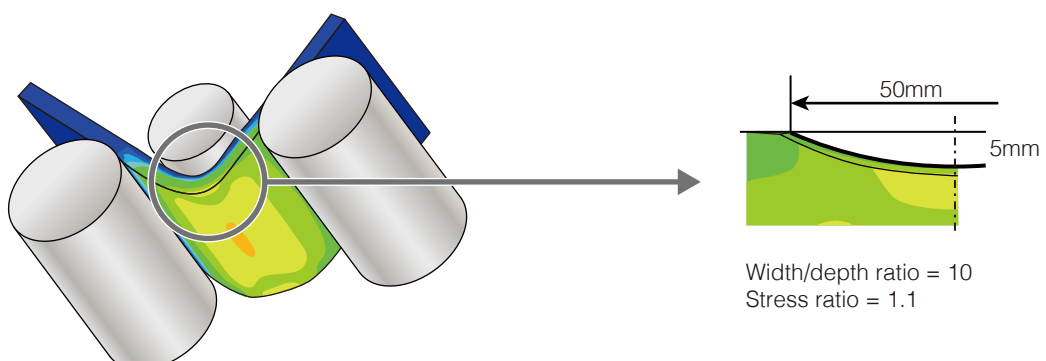



# Bending Force

Necessary bending force can be calculated. Please calculate the necessary force and select an appropriate forming device. If there are scratches or flaws on the pressing tool (punch) or receiving tool (die), and/or the surface is in poor condition, those flaws may be transferred to the surface of the EVERHARD steel plate, resulting in stress concentration. The tool surfaces, therefore, should be inspected before forming and a smooth condition should be secured.

The bending force can be calculated by the following formula.

$$P[\text{ton}] = 1.7 \times \frac{W \cdot t^2 \cdot \sigma_B}{9865 \cdot S}$$

- Strength of steel plate: If  $\sigma_B$  becomes 1.5 times higher (1.5x), then the bending force also gets 1.5 times bigger (1.5x).
- Thickness of steel plate: The bending force is proportional to the square of  $t$ . If  $t$  gets doubled (2.0x) bending force will be roughly 4 times (4.0x).
- The relationship between thickness, bending force and plate strength is as shown in the following figures.

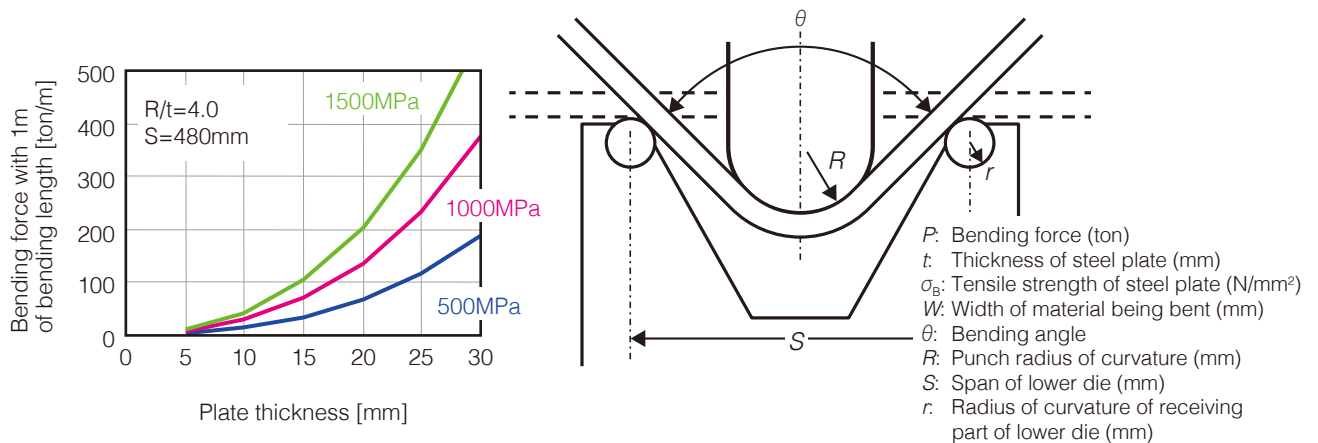

## Relationship between plate thickness and necessary bending force with various plate strength

EVERHARD or other high strength materials have large limit bending radius. And larger punch radius is adopted resulting in larger bending force than that given by the above formula. In such cases, enlarging the span of the lower die, making the clearance between the punch and the lower die larger, reduces the increase rate of the bending force with plate strength. The following formula is used in rough calculations.

$$P[\text{ton}] = \frac{1}{9865} \cdot \frac{W \cdot t \cdot \sigma_B}{\frac{S}{R} \cdot \frac{R}{t} - 2 \cdot \left( \frac{R}{t} + \frac{r}{t} + 1 \right) \cdot \cos\left(\frac{\theta}{2}\right)}$$

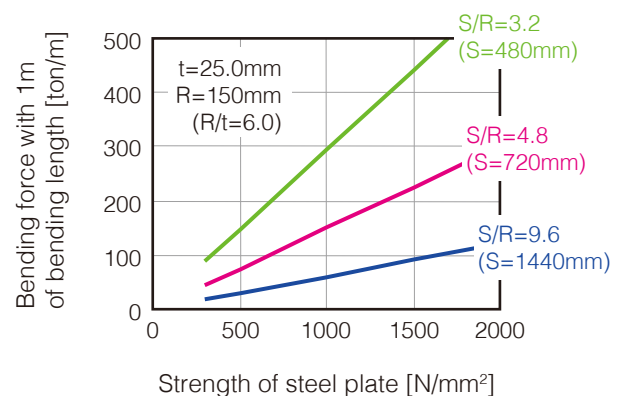
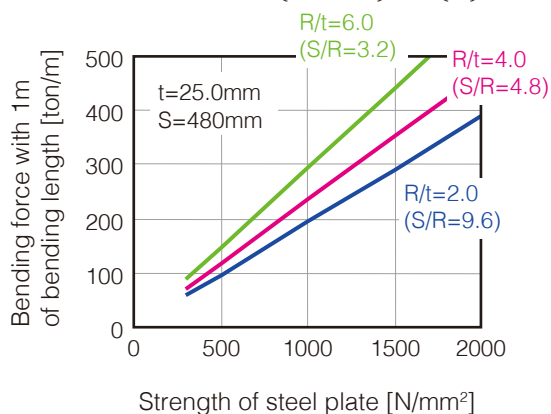

## Difference in bending force depending on punch radius and span of lower die

## ■ Guidelines for Standard Bending Force

### ■ Case of bending perpendicular to rolling direction, plate thickness 20 mm, lower die span S/R=4

Brand name	Tensile strength (N/mm <sup>2</sup> )	Punch radius of curvature (R/t)	Bending force per 1 m of plate width (ton/m)
JFE-HITEN780LE	875	2.0	537(S=160mm)
JFE-HITEN980S	1075	2.5	487(S=200mm)
EVERHARD-C340	1080	3.0	388(S=240mm)
EVERHARD-C400	1316	4.5	291(S=360mm)
EVERHARD-C400LE	1312	4.5	290(S=360mm)
EVERHARD-C450	1459	5.5	257(S=440mm)
EVERHARD-C450LE	1463	5.5	258(S=440mm)
EVERHARD-C500	1711	6.5	250(S=520mm)
EVERHARD-C500LE	1737	6.5	254(S=520mm)
EVERHARD-SP	1349	5.5	237(S=440mm)

### ■ Case of bending perpendicular to rolling direction, plate thickness 20 mm, lower die span S=400 mm (S/t=20)

Brand name	Tensile strength (N/mm <sup>2</sup> )	Punch radius of curvature (R/t)	Bending force per 1 m of plate width (ton/m)
JFE-HITEN780LE	875	2.0	130
JFE-HITEN980S	1075	2.5	166
EVERHARD-C340	1080	3.0	174
EVERHARD-C400	1316	4.5	245
EVERHARD-C400LE	1312	4.5	244
EVERHARD-C450	1459	5.5	302
EVERHARD-C450LE	1463	5.5	303
EVERHARD-C500	1711	6.5	400
EVERHARD-C500LE	1737	6.5	406
EVERHARD-SP	1349	5.5	279

# Springback

Springback (change in bent angle after unloading) is unavoidable, particularly when high strength steel plate is bent. The amount of springback can be calculated by the following formula. This can be used as a guideline for shaping.

The following figures show the relationship between the amount of springback, the plate strength and thickness in the case of 90° bending ( $\theta_{off} = 90^\circ$ ) as an example. These figures should be used when determining bending conditions.

$$\Delta\theta = \theta_{off} - \theta_{on} = 5 \cdot \frac{\sigma_B \cdot R}{E \cdot t} \cdot (180 - \theta_{on})$$

- $\Delta\theta$ : Change in angle due to springback
- $\sigma_B$ : Tensile strength of steel plate (N/mm<sup>2</sup>)
- $t$ : Thickness of steel plate (mm)
- $R$ : Punch radius (mm)
- $\theta_{on}$ : Bending angle with bending force
- $\theta_{off}$ : Bending angle after unloading
- $E$ : Young's modulus of steel plate (=206000 N/mm<sup>2</sup>)

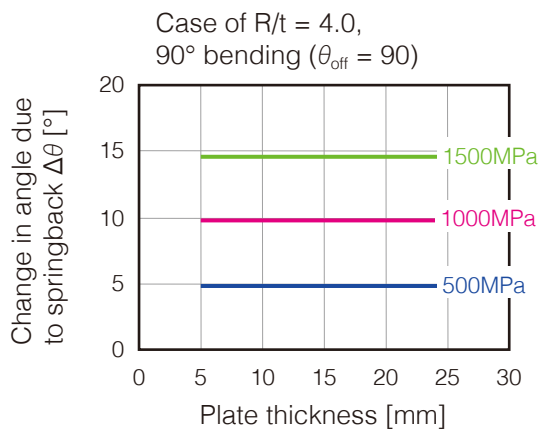
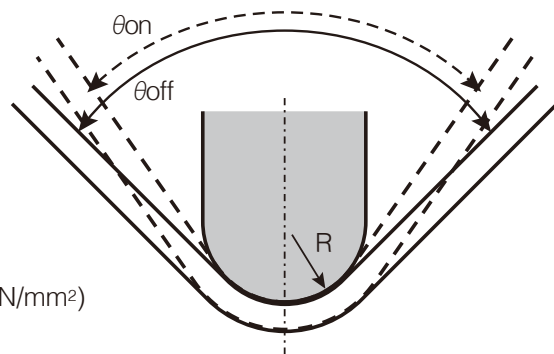

(a) Case when  $R/t$  is constant

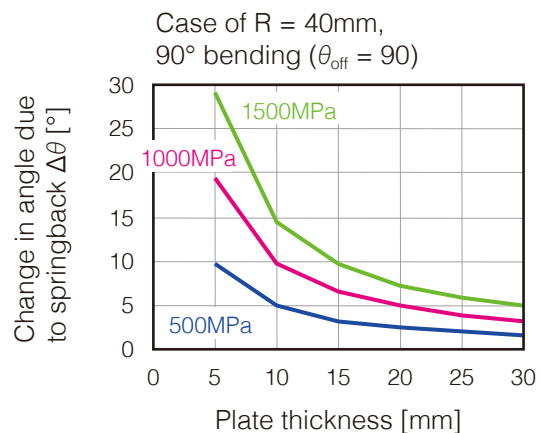

(b) Case when  $R$  is constant

## Relationship between plate thickness and strength and change in angle due to springback

The changes due to the strength and thickness of a steel plate and bending conditions are as follows.

- In 90° bending ( $\theta_{off} = 90^\circ$ ) of a steel plate with strength of 1000 MPa, springback is approximately 10°.\*
- If the strength of the steel plate becomes 1.5 times (1.5x), amount of springback will also be 1.5 times (1.5x).
- In case the ratio of the punch radius to plate thickness ( $R/t$ ) is constant, the thickness of the steel plate has virtually no effect on amount of springback.
- If the punch radius is constant and the thickness of the steel plate becomes half (0.5x), amount of springback will be approximately doubled (2.0x).
- If the punch radius becomes 1.5 times (1.5x), amount of springback will also be approximately 1.5 times (1.5x).
- If the bending angle becomes 1.5 times bigger (1.5x), amount of springback will also be approximately 1.5 times (1.5x).

\* In that case, the bending angle under pressure ( $\theta_{on}$ ) becomes approximately 80°.

**JFE Steel Corporation**<http://www.jfe-steel.co.jp/en/>**HEAD OFFICE**

Hibiya Kokusai Building, 2-3 Uchisaiwaicho 2-chome, Chiyodaku, Tokyo 100-0011, Japan Phone: (81)3-3597-3111 Fax: (81)3-3597-4860

**ASIA PACIFIC****SEOUL**JFE Steel Korea Corporation  
16th Floor, 41, Cheonggyecheon-ro, Jongno-gu, Seoul,  
03188, Korea  
(Youngpung Building, Seorin-dong)  
Phone: (82)2-399-6337 Fax: (82)2-399-6347**BEIJING**JFE Steel Corporation Beijing  
1009 Beijing Fortune Building No.5, Dongsanhuan  
North Road, Chaoyang District, Beijing, 100004,  
P.R.China  
Phone: (86)10-6590-9051 Fax: (86)10-6590-9056**SHANGHAI**JFE Consulting (Shanghai) Co., Ltd.  
Room 801, Building A, Far East International Plaza,  
319 Xianxia Road, Shanghai 200051, P.R.China  
Phone: (86)21-6235-1345 Fax: (86)21-6235-1346**GUANGZHOU**JFE Consulting (Guangzhou) Co., Ltd.  
Room 3901 Citic Plaza, 233 Tian He North Road,  
Guangzhou, 510613, P.R.China  
Phone: (86)20-3891-2467 Fax: (86)20-3891-2469**MANILA**JFE Steel Corporation, Manila Office  
23rd Floor 6788 Ayala Avenue, Oledan Square,  
Makati City, Metro Manila, Philippines  
Phone: (63)2-886-7432 Fax: (63)2-886-7315**HO CHI MINH CITY**JFE Steel Vietnam Co., Ltd.  
Unit 1704, 17th Floor, MPlaza, 39 Le Duan Street,  
Dist 1, HCMC, Vietnam  
Phone: (84)28-3825-8576 Fax: (84)28-3825-8562**HANOI**JFE Steel Vietnam Co., Ltd., Hanoi Branch  
Unit 1501, 15th Floor, Cornerstone Building, 16 Phan  
Chu Trinh Street, Hoan Kiem Dist., Hanoi, Vietnam  
Phone: (84)24-3855-2266 Fax: (84)24-3533-1166**BANGKOK**JFE Steel (Thailand) Ltd.  
22nd Floor, Abdulrahim Place 990, Rama IV Road,  
Silom, Bangrak, Bangkok 10500, Thailand  
Phone: (66)2-636-1886 Fax: (66)2-636-1891**YANGON**JFE Steel (Thailand) Ltd., Yangon Office  
Unit 05-01, Union Business Center, Nat Mauk Road,  
Bocho Quarter, Bahan Tsp, Yangon, 11201, Myanmar  
Phone: (95)1-860-3352**SINGAPORE**JFE Steel Asia Pte. Ltd.  
16 Raffles Quay, No.15-03, Hong Leong Building,  
048581, Singapore  
Phone: (65)6220-1174 Fax: (65)6224-8357**JAKARTA**PT. JFE STEEL INDONESIA  
6th Floor Summitmas II, JL Jendral Sudirman Kav.  
61-62, Jakarta 12190, Indonesia  
Phone: (62)21-522-6405 Fax: (62)21-522-6408**NEW DELHI**JFE Steel India Private Limited  
806, 8th Floor, Tower-B, Unitech Signature Towers,  
South City-I, NH-8, Gurgaon-122001, Haryana, India  
Phone: (91)124-426-4981 Fax: (91)124-426-4982**MUMBAI**JFE Steel India Private Limited, Mumbai Office  
603-604, A Wing, 215 Atrium Building, Andheri-Kurla  
Road, Andheri (East), Mumbai-400093, Maharashtra,  
India  
Phone: (91)22-3076-2760 Fax: (91)22-3076-2764**CHENNAI**JFE Steel India Private Limited, Chennai Office  
No.86, Ground Floor, Polyhose Towers(SPIC Annexe),  
Mount Road, Guindy, Chennai-600032, Tamil Nadu,  
India  
Phone: (91)44-2230-0285 Fax: (91)44-2230-0287**BRISBANE**JFE Steel Australia Resources Pty Ltd.  
Level28, 12 Creek Street, Brisbane QLD 4000  
Australia  
Phone: (61)7-3229-3855 Fax: (61)7-3229-4377**EUROPE and MIDDLE EAST****LONDON**JFE Steel Europe Limited  
15th Floor, The Broadgate Tower, 20 Primrose Street,  
London EC2A 2EW, U.K.  
Phone: (44)20-7426-0166 Fax: (44)20-7247-0168**DUBAI**JFE Steel Corporation, Dubai Office  
P.O.Box 261791 LOB19-1208, Jebel Ali Free Zone  
Dubai, U.A.E.  
Phone: (971)4-884-1833 Fax: (971)4-884-1472**NORTH, CENTRAL and SOUTH AMERICA****NEW YORK**JFE Steel America, Inc.  
600 Third Avenue, 12th Floor, New York, NY 10016,  
U.S.A.  
Phone: (1)212-310-9320 Fax: (1)212-308-9292**HOUSTON**JFE Steel America, Inc., Houston Office  
750 Town & Country Blvd., Suite 705 Houston,  
Texas 77024, U.S.A.  
Phone: (1)713-532-0052 Fax: (1)713-532-0062**MEXICO CITY**JFE Steel America, Inc., Mexico Office  
Ruben Dario #281-1002, Col. Bosque de  
Chapultepec, C.P. 11580, CDMX. D.F. Mexico  
Phone: (52)55-5985-0097 Fax: (52)55-5985-0099**RIO DE JANEIRO**JFE Steel do Brasil LTDA  
Praia de Botafogo, 228 Setor B, Salas 508 & 509,  
Botafogo, CEP 22250-040, Rio de Janeiro-RJ, Brazil  
Phone: (55)21-2553-1132 Fax: (55)21-2553-3430**Notice**

While every effort has been made to ensure the accuracy of the information contained within this publication, the use of the information is at the reader's risk and no warranty is implied or expressed by JFE Steel Corporation with respect to the use of information contained herein. The information in this publication is subject to change or modification without notice. Please contact the JFE Steel office for the latest information.